



Combination controls

CG 10



Combination controls CG 10

- /// Complete with strainer, two solenoid valves and servo-governor for maximum regulation precision.
- /// Special low-noise valves.
- /// Optional pressure switch at the inlet.
- /// Easy-to-service. All adjustment and metering facilities, with the addition of the electrical connections, are accessible from one side.
- /// Flow rate adjustment for precise adjustment of the max. flow rate.
- /// Environment-friendly thanks to recyclable and resource-friendly design, plastic parts with material identification.
- /// EC type-tested and certified design.
- /// **CE**



Application

For safeguarding and controlling atmospheric burners, forced draught gas burners and induced-draught boilers on heating installations up to 50 kW. Combination controls CG..G, CG..V2 and CG..V3 can also be used on steam boiler installations to TRD 412. The combination controls are EC type-tested and certified pursuant to the Gas Appliance Directive (90/396/EEC) in conjunction with EN 126.

Examples of application

CG..D1 CG..D2

Single-stage, special-purpose gas heating boilers, single-stage wall heating boilers, pre-mixers.

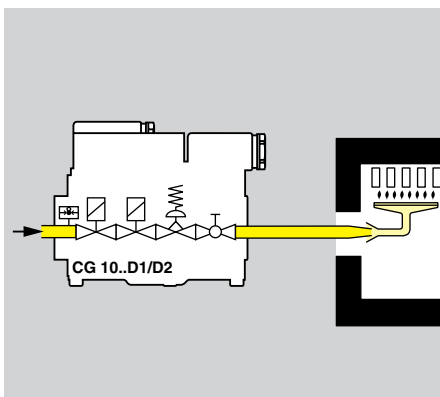

CG..D1 CG..D2

Hearths.

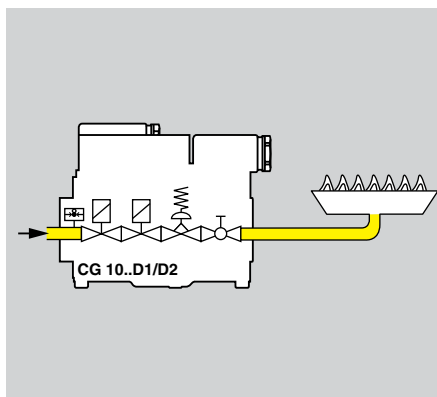

CG..D1 CG..D2

Units, single-stage forced draught gas burners, burners with mechanical capacity adjustment.

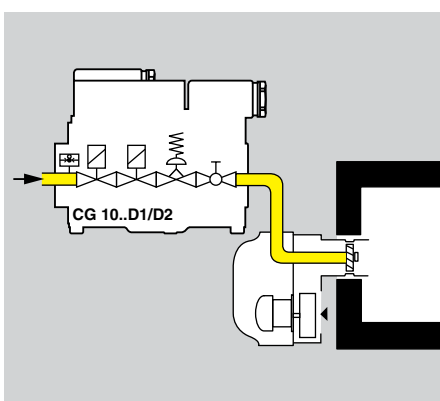

CG..G*

Draught-assisted boilers, modulating or multi-stage control.

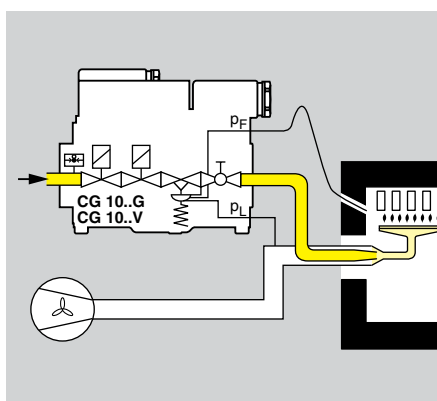

CG..V

Fan and draught-assisted boilers, modulating or two-stage control.

CG..D1 CG..D2

Radiant plaques, industrial heating systems, radiant tube heaters, space heaters.

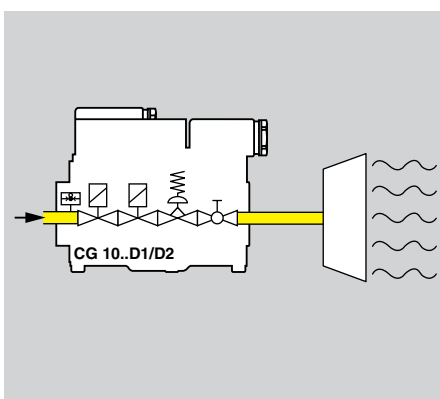

CG..G*

Boilers with flue-gas, induced-draught fan.

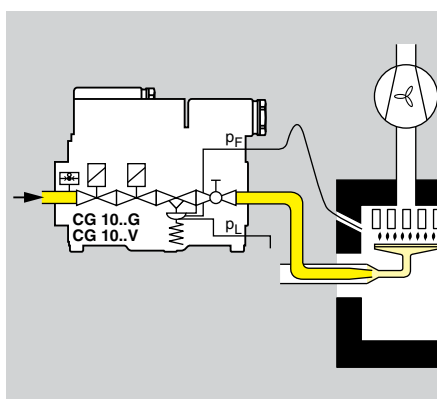

CG..V

Boilers with flue-gas induced-draught fan.

*CG..G without connection for combustion chamber pressure p_F

CG..G*

Forced draught burners, modulating or two-stage control.

CG..V

Forced draught burners, modulating or multi-stage control.

* CG..G without connection for combustion chamber pressure p_F

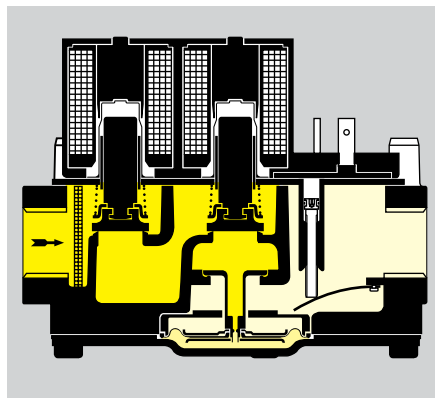
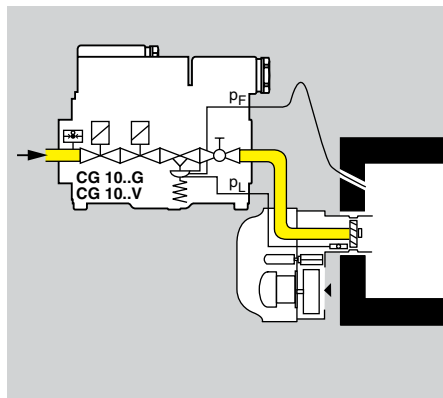

Function

When the voltage is applied, the two solenoid valves open. The servo-governor achieves a high regulating precision regardless of changing inlet pressures.

Features

- 2 solenoid valves, class A or B.
- CG..D1 with constant pressure governor.
- CG..D2 with constant pressure governor with start load.
- CG..G with air/gas ratio control, ratio of

gas pressure to air pressure 1:1.

- CG..V2 and CG..V3 with variable air/gas ratio control, ratio of gas pressure to air pressure 2:1 or 3:1.
- Inlet pressure switch DG..C can be fitted at the works (cannot be fitted retrospectively).
- With flow rate adjustment.

Technical data

Types of gas: natural gas and LPG (gaseous).

Inlet pressure range p_e : 15 to 70 mbar.

Ambient temperature: 0 to +70°C.

Storage temperature: -20 to +50°C.

Threaded connection: Rp 1/2 in accordance with ISO 7-1.

Threaded connection, control lines p_L , p_F : Rp 1/8 (CG..G, CG..V2 and CG..V3 only)

Pressure test points on inlet and outlet.

Housing components: AISi.

Diaphragms: Perbunan.

Strainer: plastic fabric.

Solenoid valves (class A or B) with spring-loaded valve disc, normally closed (when de-energised).

Switching frequency: any.

Closing time: <1 s.

Mains voltage:

230 V, -15/+10 %, 50/60 Hz, $\cos \varphi = 1$

206 V, -15/+10 %, DC voltage

24 V, ± 15 %, 50/60 Hz, $\cos \varphi = 1$

20 V, ± 15 %, DC voltage.

Power consumption:

A valves: 24 W

B valves: 18 W

The electrical power is the same when switching on as in continuous operation.

Duty cycle: 100 % duty.

Protective grade IP 54 in accordance with IEC 529.

Fusing: max. 6.3 A, slow-blowing.

Electrical connection:

Coupler plug in accordance with ISO 4400 with cable gland: Pg 11.

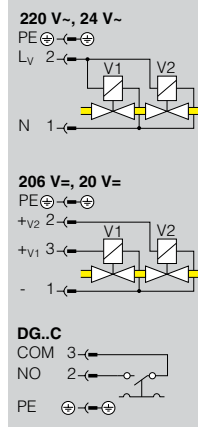

Fitting position

In vertical pipework: as required;
in horizontal pipework: inclined up to max. 90° to left/right, not upside-down, see also CG..D2: Function.

Type	Connection	Dimensions							$p_{e \text{ max.}}$ mbar	P VA/W	Weight kg
		DN	L mm	H1* mm	H2 mm	H3 mm	B1 mm	B2 mm			
CG 10..A	Rp 1/2	15	116	74	64	33	30	63	70	24	1.4
CG 10..B	Rp 1/2	15	116	59	64	33	30	63	70	18	1.2

* with rectifier adapter + 22 mm

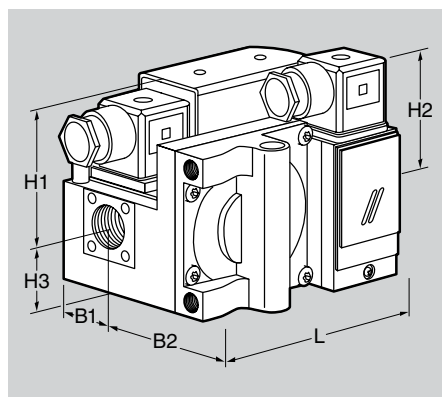

CG..D1, CG..D2

With constant governor, class C, for high regulating precision, for atmospheric burners or single-stage forced draught gas burners.

Function: Both valves open when the voltage is applied.

CG..D1: The outlet pressure rises to p_G .

CG..D2: The outlet pressure initially rises to the start pressure p_S . This is then followed by a damped pressure rise to p_G .

In fitting position "governor pointing downwards", the pressure remains constant for max. 6 sec. when the start pressure p_S is reached. Only then does a damped pressure rise to p_G occur.

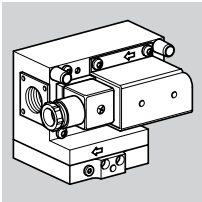

Working range:

CG..D1: The outlet pressure p_G can be adjusted by means of a spring from 5 to 40 mbar (CG..D1-20: 2.5-20 mbar).

CG..D2: The start pressure p_S can be adjusted from 2 to 15 mbar; the outlet pressure p_G can be adjusted from 5 to 40 mbar (CG..D2-20: p_S : 1-7.5 mbar, p_G : 2.5-20 mbar).

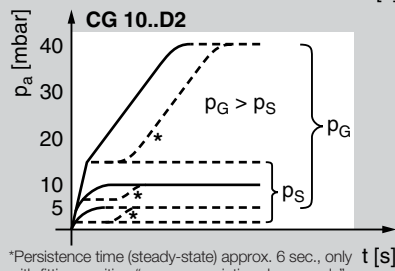
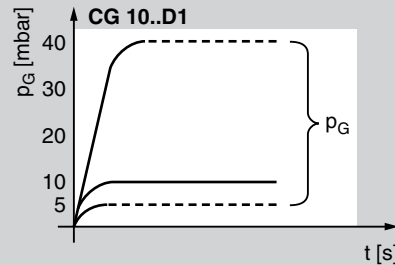
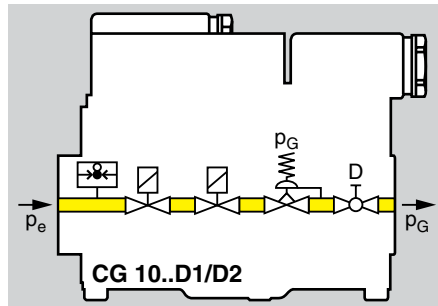

*Persistence time (steady-state) approx. 6 sec., only with fitting position "governor pointing downwards"

CG..G, CG..V2 and CG..V3

With constant governor or variable air/gas ratio control, class C, for precise pneumatic air/gas ratio control for modulating or two-stage, sliding draught burners or draught-assisted boilers.

Function: Both valves open when the voltage is applied. The CG then regulates the gas outlet pressure p_G . This pressure follows the variable air control pressure p_L . The ratio between gas and air pressure remains constant.

At min.-flow operation of the burner, the gas/air mixture can be varied through parallel shifting of the characteristic by adjusting the screw "N". High fire is adjusted with the main flow restrictor D. On the CG..V2 and CG..V3, the combustion chamber pressure can be compensated for by connection to p_F .

Working range:

Permitted gas outlet pressure:

$p_G = 0.4$ to 30 mbar.

Permitted air control pressure:

$p_L = 0.4$ to 10 mbar.

Zero offset N:

CG..G: ± 0.2 mbar

CG..V2: ± 0.4 mbar

CG..V3: ± 0.6 mbar

Gas/air ratios:

CG..G: approx. 1:1

CG..V2: approx. 2:1

CG..V3: approx. 3:1

Permitted combustion chamber pressure:

$p_F = -2$ to +5 mbar.

Minimum control pressure difference:

$p_L - p_F = 0.4$ mbar.

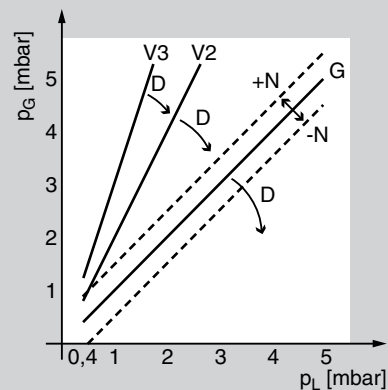
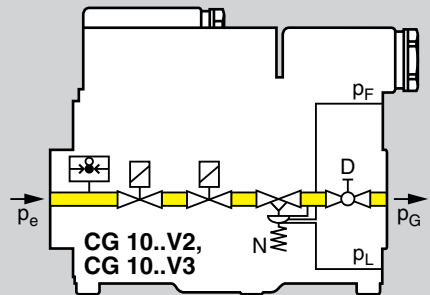
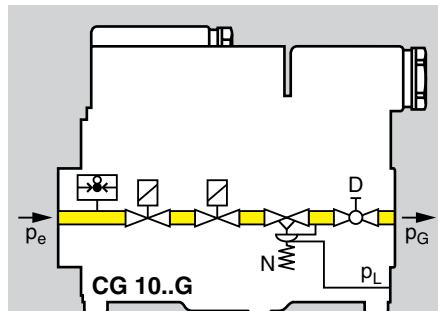

Selection examples

Outlet data:
 Type of gas: natural gas
 Min. inlet pressure p_e : 18 mbar
 Max. flow rate V_{max} : 2 m³/h
 Max. outlet pressure p_G : 10 mbar

CG..D1, CG..D2

The pressure drop Δp across the entire combination control can be calculated as follows:

$$\begin{aligned} \Delta p &= p_e - p_G \\ &= 18 - 10 \text{ mbar} \\ &= 8 \text{ mbar} \end{aligned}$$

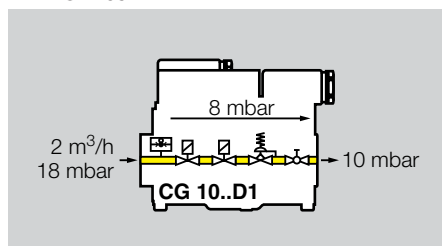

The operating point P1 ($V_{max} = 2 \text{ m}^3/\text{h}$; $\Delta p = 8 \text{ mbar}$) must lie in the working range of the combination control CG 10.

CG..G, CG..V2, CG..V3

Additional outlet data
 Max. burner air pressure p_L : 4 mbar

Determining the transmission ratio U:

$$U = \frac{p_G}{p_L} = \frac{10}{4} = 2,5$$

Select the governor type with the next higher ratio U_{min} .

Governor "G" $\rightarrow U_{min.} = 1$ ($U_{max.} = 1$)
 Governor "V2" $\rightarrow U_{min.} = 1.9$ ($U_{max.} = 2.3$)
 Governor "V3" $\rightarrow U_{min.} = 2.9$ ($U_{max.} = 3.5$)

The available pressure drop Δp can be calculated as follows:

$$\begin{aligned} \Delta p &= p_e - U_{max.} \cdot p_L \\ &= 18 - 3,5 \cdot 4 \text{ mbar} \\ &= 4 \text{ mbar} \end{aligned}$$

The operating point P2 ($V_{max} = 2 \text{ m}^3/\text{h}$; $\Delta p = 4 \text{ mbar}$) must lie in the working range of the combination control CG 10.

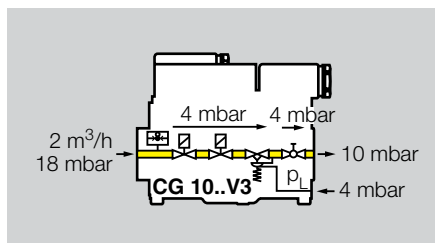

A further 4 mbar must be generated by flow rate adjustment, in addition to the computed pressure drop $\Delta p = 4 \text{ mbar}$, in order to achieve the required outlet pressure $p_G = 10 \text{ mbar}$.

At min. flow, the actual flow rate may not drop below the minimum flow rate $V_{min.}$ (see diagram).

All GC units

If the operating point does not lie in the working range of the CG 10, the inlet variables p_e , V , p_G or p_L must be adapted. We recommend a different CG control for applications with different capacity demand. See also CG 1, 2, 3, Brochure No. 5.1.2.2.

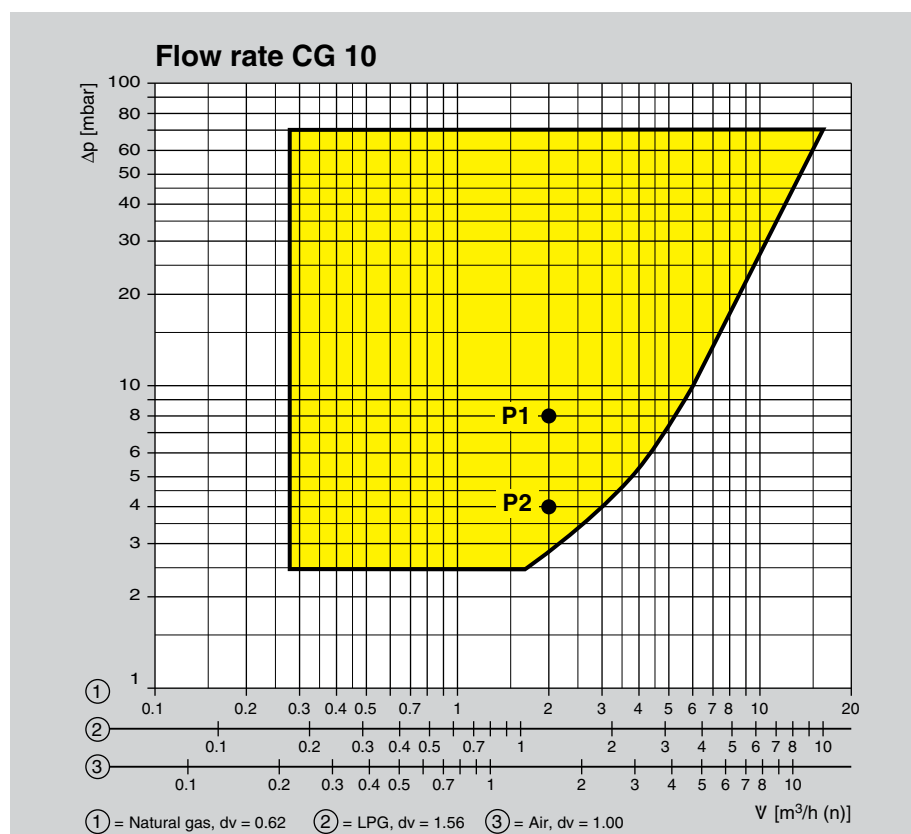

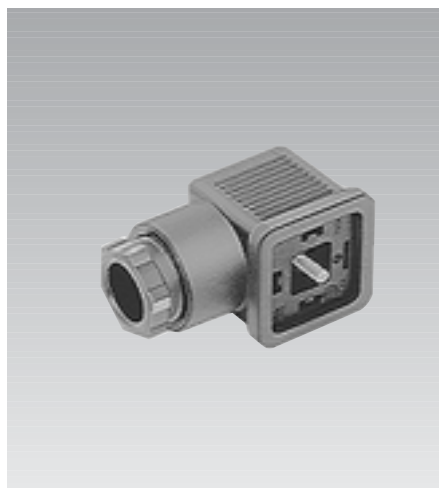

Accessories

Combination control CG 10 can be fitted at the works with a preset pressure switch for gas DG..C at the inlet as a low-pressure gas cut-out.
Pre-setting: 14 mbar.

Electrical connection: coupler plug in accordance with ISO 4400 with cable gland Pg 11.

Flanges DN 15, straight version or angle version available.

Both a rectifier adapter for interconnection and a coupler plug with rectifier are available for AC voltage.

Type code

Type	CG 10 R 70 -D1-20* W 6 A W**Z**
Size 10	
Rp thread	
Max. inlet pressure p_E 70 mbar = 70	
Governor = D1 Governor with start gas stage = D2 Air/gas ratio control = G Variable air/gas-ratio control 2:1 = V2 Variable air/gas-ratio control 3:1 = V3	
Max. outlet pressure p_G with D1 and D2: 20 mbar = 20*	
Mains voltage	20 V ₌ = L 24 V _~ = H 206 V ₌ = U 230 V _~ = W
Rectifier adapter without socket = 5 Rectifier adapter with socket = 6 Without rectifier, without socket = 8 Without rectifier, with socket = 9	
Valve class = A, B	
Pressure switch DG 35C = W*, DG 45/VC = WW**	
Special version = Z**	

* p_G = 40 mbar if "none".

** This letter is omitted if "none".

We reserve the right to make technical modifications in the interests of progress.

Kromschroder has an environment-friendly production policy. Please send away for our Environment Report.

G. Kromschroder AG
Postfach 2809
D-49018 Osnabrück
Phone: +49 (0) 5 41/12 14-0
Fax: +49 (0) 5 41/12 14-3 70
info@kromschroeder.com
www.kromschroeder.de

03250035 EP 3.00 F.T 2000 GB